



# POLYPROPYLENE TECHNOLOGY



ICRC



**ICRC**

International Committee of the Red Cross  
19, avenue de la Paix  
1202 Geneva, Switzerland  
T +41 22 734 60 01 F +41 22 733 20 57  
E-mail: [shop@icrc.org](mailto:shop@icrc.org) [www.icrc.org](http://www.icrc.org)  
© ICRC, June 2007

Front cover and inside (unless specified): ICRC/PRP

Introduction	2
The ICRC's polypropylene technology: A brief history	4
The ICRC's polypropylene system	6
International recognition	8
Training resources	9
A constantly evolving technology	10
About polypropylene	11



# INTRODUCTION

As part of its mandate, the ICRC plays an active role in the physical rehabilitation of victims of conflict and violence. Since 1979, the ICRC has diversified its activities throughout the world. The work of providing physical rehabilitation for people with disabilities, as one aspect of humanitarian assistance, was once confined to emergency response. The ICRC has gone well beyond that now, in recognition of the fact that the need for physical rehabilitation will persist throughout the lives of the disabled.

The ICRC has come to occupy a leading position in the field of physical rehabilitation, mainly on account of the worldwide scope of its activities, the technology it has developed, its expertise and its long-term commitment to the projects it supports. In most countries where the ICRC has

provided support for physical rehabilitation, such services were either non-existent or minimal. In most cases, the ICRC's support became the basis for establishing a national reintegration service.

The ultimate objective of the ICRC's efforts in this area is to make possible the socio-economic rehabilitation of the physically disabled, during and after the period in which they receive assistance from the ICRC. Providing adequate care and comfortable prosthetic and orthotic fitting for the patient is an important first step. The main aims of the ICRC's support are:

- to make rehabilitation services accessible;
- to improve the quality of such services;
- to ensure that these services continue in the long run.

# The ICRC Physical Rehabilitation Unit was established in 1979, marking the start of a long-term commitment.



Giovanni Diffidenti/IEE Photos

The role of appropriate technology<sup>1</sup> – one that is both inexpensive and of high quality – is crucial. Such technology makes rehabilitation services more affordable and thus more widely accessible. It also makes possible the production of orthopaedic devices that are durable and that conform to sound biomechanical principles. Low-cost technology also minimizes the operating expenses of rehabilitation centres and makes the long-term survival of such centres more likely.

<sup>1</sup> Appropriate technology: "A system providing proper fit and alignment based on sound biomechanical principles [that] suit the needs of the individual and can be sustained by the country at the most economical and affordable price." N. Jacobs (ed.) *Report of ISPO Consensus Conference on Appropriate Orthopaedic Technology for Developing Countries*, ISPO, Phnom Penh, 1995, p.8.



## THE ICRC'S POLYPROPYLENE

In the beginning, the ICRC relied on imported materials to manufacture orthopaedic devices in developing countries.

It became obvious quickly that while it was possible to produce orthopaedic devices of high quality with such materials, it was also prohibitively expensive and often of limited usefulness.

Because importing orthopaedic components was simply too expensive, the ICRC began to develop and produce them on its own. At first, the ICRC used locally available materials; this changed in 1991 when thermoplastics became the ICRC's raw material of choice. The advantages of using polypropylene soon became obvious.

While the first polypropylene knee joint was produced in Cambodia in 1991, various alignment systems were developed in Colombia in the same period and, gradually, improvements were made to them. In 1993, the ICRC produced its first components made of polypropylene.





## TECHNOLOGY: A BRIEF HISTORY

At that time, orthopaedic components were made by recycling material left over from the production of sockets.

Today, in most countries where the ICRC's polypropylene technology is in use, such waste material is recycled to make components for walking aids.

The ICRC's polypropylene technology has gradually developed since its beginnings. Components for all kinds of lower and upper limb prostheses are now available.

The ICRC chose polypropylene for a number of reasons:

- it is relatively cheap;
- it has a long shelf life (it is long-lasting and can be stored easily);
- it requires very few other materials in the manufacturing process;
- it is easy to process and versatile;
- it is recyclable.

The ICRC's polypropylene technology has been developed to manufacture prosthetic devices with the following considerations in mind:

- The devices / components have to be durable, comfortable, and easy for patients to use and to maintain;
- The technology has to be simple and easy to put into practice;
- The devices / components have to be compatible with the climate in different regions of the world;
- The technology has to be inexpensive and consistent with internationally accepted standards;
- The technology has to be flexible enough to accommodate the needs of every individual.



# THE ICRC'S POLYPROPYLENE SYSTEM

The design of the components permits prosthetic fitting at every level of amputation for the lower and the upper limbs.

Trans-Femoral prosthesis setup

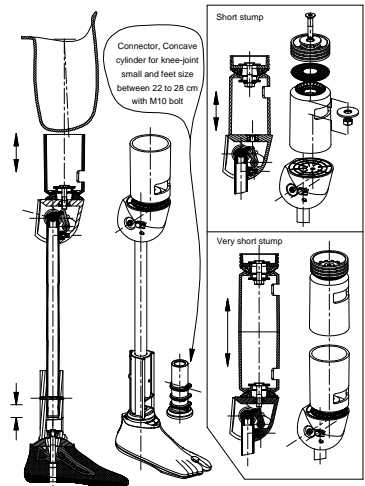

Knee-disarticulation setup

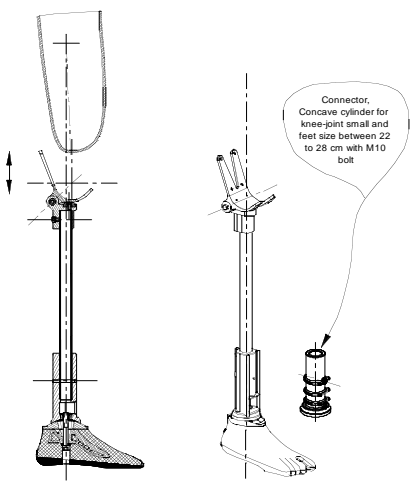

Hip-disarticulation setup

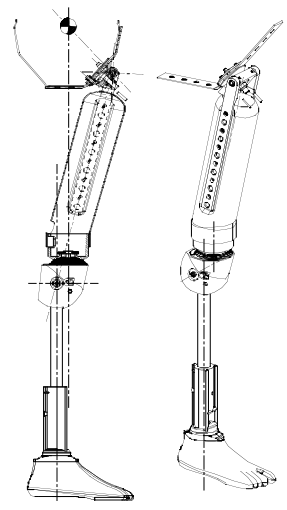



### Trans-Tibial prosthesis setup

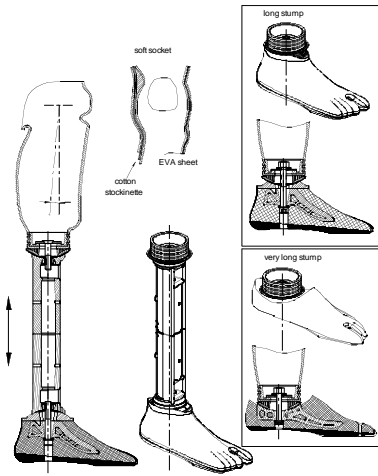

### Trans-Humerus prosthesis description & setup

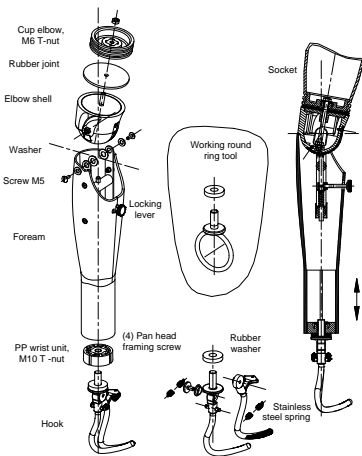

Polypropylene provides the core for the prosthetic system developed by the ICRC. The injection process is used for making the components.

The other parts of the assistive devices (sockets, cosmetic covers, etc) are made out of polypropylene sheets using thermoforming.



## INTERNATIONAL RECOGNITION

In 2004, the ICRC was awarded the Brian Blatchford Prize by the International Society for Prosthetics and Orthotics (ISPO). This was in recognition of the ICRC's role in making rehabilitation devices more readily available by developing and propagating low-cost, high-quality polypropylene technology. This technology has become a standard in prosthetics and is being used by an increasing number of organizations.

### THE BRIAN BLATCHFORD PRIZE

"... in recognition of its innovative achievements, particularly in the design and development of the polypropylene prosthetic system, which over the years has become a standard for appropriate and low cost prosthetic services in developing countries."

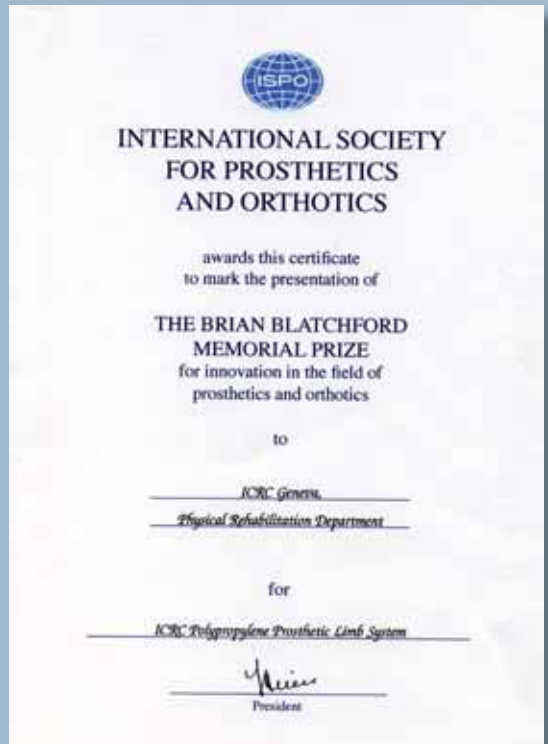



# TRAINING RESOURCES

The ICRC has developed short training courses and manuals of manufacturing guidelines to introduce professionals to the use of its polypropylene technology.

In addition, the ICRC Special Fund for the Disabled has helped accredited schools – those classified by the ISPO as “Category II” – to incorporate polypropylene technology into their curricula.

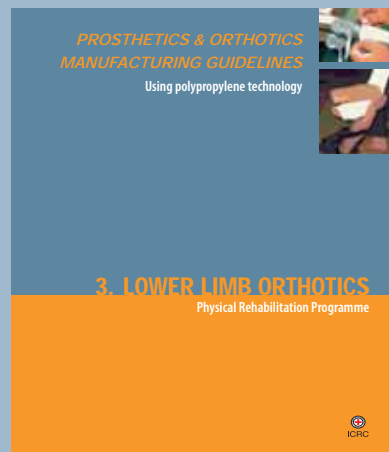
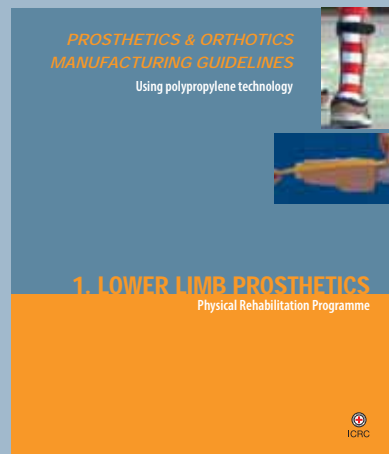
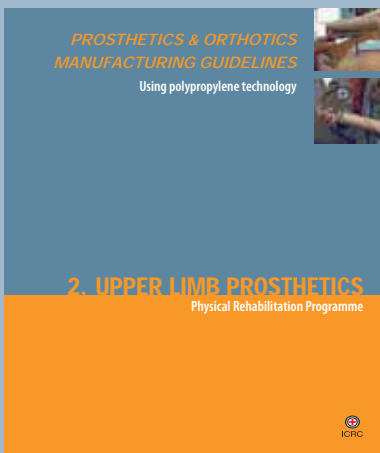



## A CONSTANTLY EVOLVING TECHNOLOGY

Every year, ICRC-supported physical rehabilitation centres use the organization's polypropylene technology to produce tens of thousands of orthopaedic appliances throughout the world. A large number of non-governmental organizations have also adopted this technology.

Over the years, several test reports published by the ISPO have endorsed the ICRC's polypropylene technology for use in developing countries.<sup>2</sup>

The ICRC constantly monitors the performance of its various orthopaedic products to ensure their high quality.

The ICRC's efforts to widen the range of its products through research conducted together with its supplier<sup>3</sup> and to improve its polypropylene technology are unceasing. As a result, these devices have benefited recently: knee and hip disarticulation prosthetic joints and prosthetic feet for long trans-tibial stumps.

<sup>2</sup>"The [polypropylene] prosthetic technology [...] is an attractive and durable solution for trans-tibial amputees, which can be recommended," ISPO report Field test on Trans. tibial prostheses (Heim & Jensen, 2000) page 54.

"The ICRC polypropylene system do live to clinical acceptable standards" – ICRC polypropylene technology for Trans-femoral amputees (Raab & Jensen 2004) ISPO 11<sup>th</sup> world congress report 2004.

<sup>3</sup>CREquipements SA. Coppet, Switzerland ([www.Crequipements.ch](http://www.Crequipements.ch)).



## ABOUT POLYPROPYLENE TECHNOLOGY

Polypropylene was discovered in the early 1950s by an Italian chemist, Giulio Natta (1903–1979). He was awarded the Nobel Prize for Chemistry in 1963.

In 1957, polypropylene was produced industrially by the Italian chemical company, Montecatini. Its overproduction and its low cost resulted in many commercial uses being found for the new material. In modern science, inventions often occur in different places simultaneously. Polypropylene is an extreme instance of this phenomenon: it was independently invented about nine times. It is a near sibling to one of its predecessors, polyethylene. Like polyethylene, polypropylene is inexpensive, but it is much more rugged. It is a thermoplastic polymer with many applications – from plastic bottles to carpets to plastic furniture – and is very heavily used in automobiles.

Two types of polypropylene are used in prosthetics and orthotics:

**Co-polymer** (more than 5% polyethylene is used in the polymerization process);

**Homopolymer** (less than 5% of polyethylene is used in the polymerization process).

Polypropylene can't be dissolved and is difficult to glue. It is UV-sensitive but certain additives can make it more resistant. It becomes more brittle at low temperatures.

Polypropylene can be made less brittle and more flexible by means of co-polymerization with polyethylene.

# PUBLICATIONS AND FILMS

More ICRC publications, technical resources and films are available on [www.icrc.org](http://www.icrc.org)

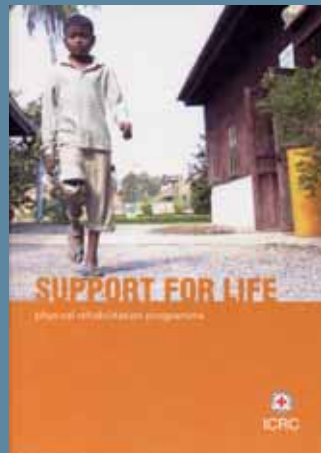
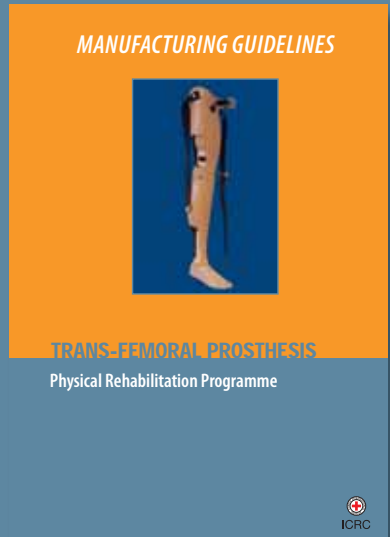
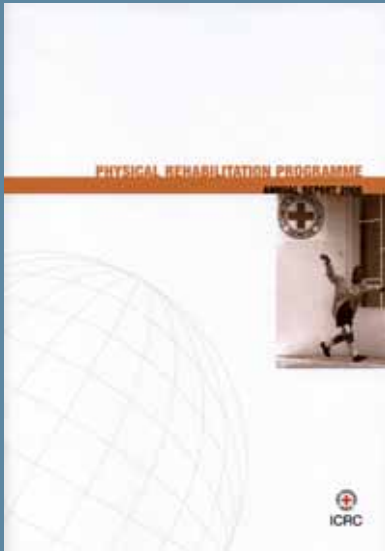

**MISSION**

The International Committee of the Red Cross (ICRC) is an impartial, neutral and independent organization whose exclusively humanitarian mission is to protect the lives and dignity of victims of armed conflict and other situations of violence and to provide them with assistance. The ICRC also endeavours to prevent suffering by promoting and strengthening humanitarian law and universal humanitarian principles. Established in 1863, the ICRC is at the origin of the Geneva Conventions and the International Red Cross and Red Crescent Movement. It directs and coordinates the international activities conducted by the Movement in armed conflicts and other situations of violence.



ICRC